

Infinity Supercritical CO2 Pump Custom Built

SIDE VIEW

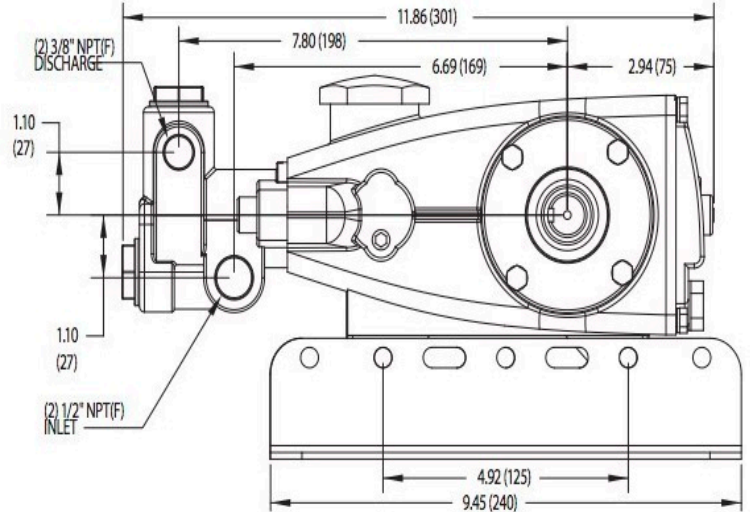
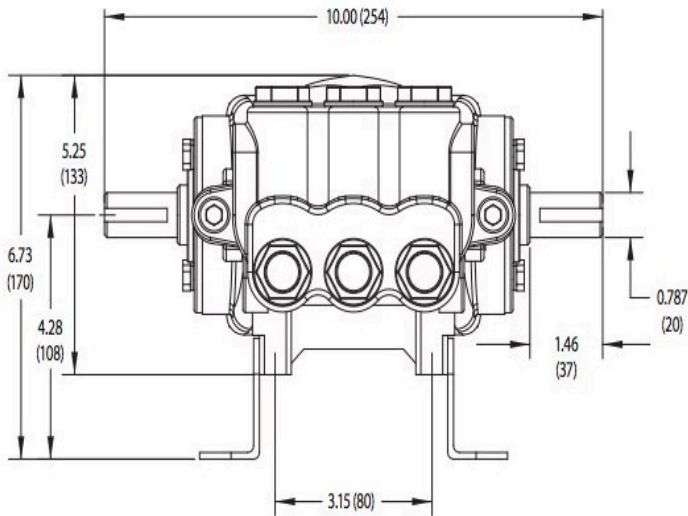

Crank Case

SIDE VIEW

Infinity Supercritical CO2 Pump
Custom Built
EXPLODED VIEW
4/11/2019

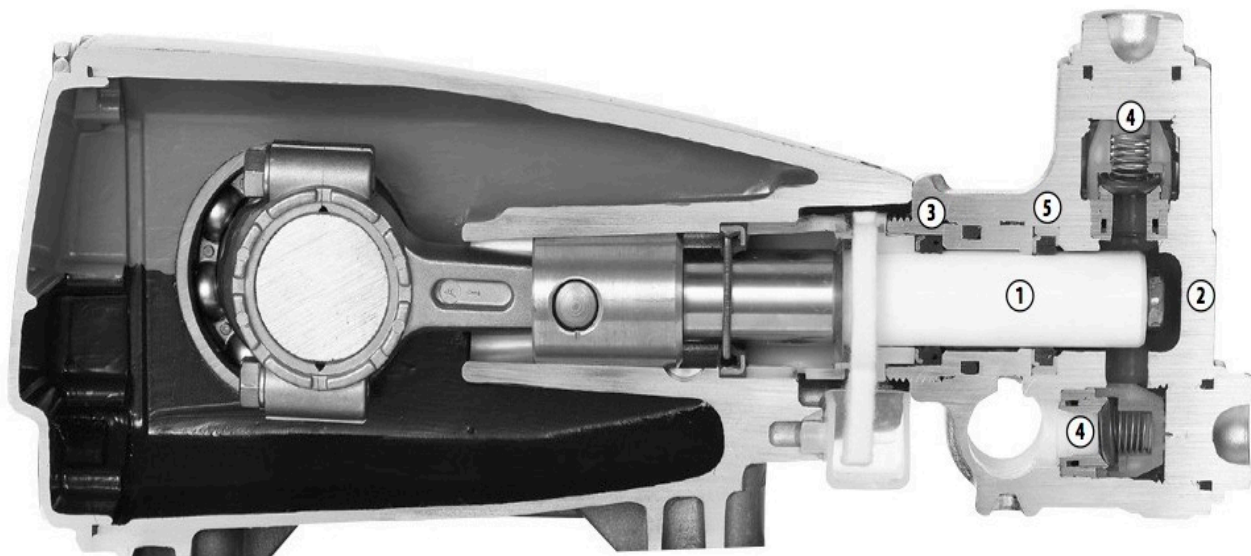

1. Special concentric, high-density, polished, solid ceramic plungers provide true wear surface and extended seal life. Infinity custom manufactures the spring energized seals for these plunger pistons.
2. Manifolds are high tensile strength forged brass or special brass for longevity, continuous duty and compatibility.

3. 100 Percent wet seal design extends service life by allowing pumped liquids to cool and lubricate on both sides.

4. Stainless steel valves, seats, and springs provide corrosion-resistance, ultimate seating and extended life.

5. High pressure seals offer performance and seal life.

6. Infinity tests these pumps on CO2 prior to shipping to customers for quality service.
7. Proper and regular operator cleaning of the CO2 system, will insure long life. Poor maintenance and cleaning will result if short pump seal life. Consumables are the pump o-rings, seals, and valves.